

HSAJET®

Product Overview

HSAJET® DOD PRINTERS & CONTROLLERS

HSAJET® products based on piezo inkjet technology



XJ128 PRINTER
17.5 mm COMPACT
PRINTHEAD

CU2-XJ128

HSAJET® XAAR Piezo Inkjet

The HSAJET® range of drop-on-demand printers are based on Xaar piezo inkjet technology, and they are ideal for outer case and product coding.

Available in a wide range of print heights and configurations, HSA Systems provides one of the most flexible product coding solutions for this technology, able to meet the requirements in a wide range of industries.

Piezo inkjet printers are used in numerous industrial applications. They eliminate the need for costly additional labelling, pre-printed stock and can replace old, single-message roller coders.

Due to the modular construction, HSA Systems can provide Piezo inkjet printing from 17.5 mm print height to more than 1000 mm print height from the same controller.

With a wide range of controllers to choose from, HSA Systems can provide a solution tailored to your production environment, from a simple terminal to fully database driven automation across the factory.

All printers can be installed either in-line or off-line and offer great flexibility due to individual controlling of each head.

HSAJET® XAAR key-features:

- Low cost per print.
- High uptime - ink change while printing.
- Robust and reliable printers, almost no maintenance.
- Very simple setup and alignment, up to 1000 mm print height.
- Up to 70 mm print height without any printhead alignment.
- A wide range of inks available, from oil based in different colours to UV solvent based for difficult substrates.
- Non-contact coding. Ideal for rough surfaces like Tyvek, wood, pallets and cardboard.
- Throw distance approximately 5 mm dependent on ink and line speed.
- Large ink supply, 0.5 or 1.0 litre ink bottles.

Key features

PRINT ENGINES

ENGINES	XAAR 128 80-4.25	XAAR 128 40-8.3	XAAR 128 80-5.5
PRINT HEIGHTS	17.5 mm	•	•
	17.5 mm High Speed	•	•
	35.0 mm	•	•
	35.0 mm High Speed	•	•
	52.5 mm	•	•
	70.0 mm	•	•
Max speed @ dpi	Standard version 35 m/min @ 185 x 185 dpi	35 m/min @ 185 x 360 dpi	35 m/min @ 185 x 185 dpi
	High Speed Version 70 m/min @ 185 x 185 dpi	70 m/min @ 185 x 360 dpi	90 m/min @ 185 x 185 dpi
SPECIFICATIONS	Nozzle plate	non-wetting	non-wetting
	Active nozzles	128	128
	Drop volume* (pL)	80	40
	Drop velocity (m/s)	5,0	6,0
	Max. Frequency (kHz)	4,25	8,3
	Colour of insulator	Blue	Dark grey

GLOSSARY

Active nozzles

Number of nozzles that fire a drop. The XJ128 has 128 active nozzles.

Drop velocity (m/s)

The linear speed of ink droplet as it leaves the printhead.

Drop volume (pL)

Size of each ink droplet. Measured in picoLitre (pL).

Engine

The module (head) that outputs the ink. Available in different models.

Max. frequency (kHz)

How many drops per second a print engine can produce.

Measured in 1000 /second (kHz).

Max. speed @ dpi

The maximum possible linear speed at a specific resolution.

Nozzle plate

The area of the printhead that forms the ink drop through movement.

Wetting

A print engine with a coating that allows the ink to remain on the nozzle plate, minimizing interference with the drop formation. Effectively, a higher speed is thereby possible.

Non-wetting

Coating that is designed to allow ink to bead away from nozzle plate. This type generally requires less maintenance.

UMBILICAL



Compact.
No umbilical



Straight.
Umbilical in
optional length



Elbow.
Umbilical in
optional length

An umbilical provides extra flexibility when installing the printer and it is essential for all applications for top/down printing.

The connection between the umbilical and the printhead is available with a straight connection or with an elbow connection.

If no umbilical is required, the printers are available as compact models.

XJ128 umbilical length

The umbilical is available in standard lengths of 10-100 cm.

Technical Details

HSAJET® DOD PRINTERS & CONTROLLERS

PRINTER	PRINT-HEAD	CU2		TIPC15/OPC (1xCB)		OPC (2xCB)		RPC (3xCB)		RPC (4xCB)	
		Max no of printers	Max printheight	Max no of printers	Max printheight	Max no of printers	Max printheight	Max no of printers	Max printheight	Max no of printers	Max printheight
XJ128	17.5 mm	8	140 mm	16	280 mm	32	560 mm	48	840 mm	64	1120 mm
XJ128	35 mm	4	140 mm	8	280 mm	16	560 mm	24	840 mm	32	1120 mm
XJ128	52.5 mm	2	105 mm	4	210 mm	8	420 mm	12	630 mm	16	840 mm
XJ128	70 mm	2	140 mm	4	280 mm	8	560 mm	12	840 mm	16	1120 mm

Technology

XAAR Piezo drop-on-demand

Print distance

0.5-2.0 mm

(nozzle to print surface)

Control panel

Keypad / LED-signal

Purge button

Reset button

Interface

Controller connection (SUB D25)

Daisy chain to next printer (SUB D25)

Signals

Low ink signal

Complies to

CE directives

Housing

Stainless steel

Weight

1.8 kg / 4 lbs (without printhead)

Accessories

- Sensor and encoder
- Bridges & Brackets
- Mountings (Inocon 53 mm)
- Controllers (see page overleaf)

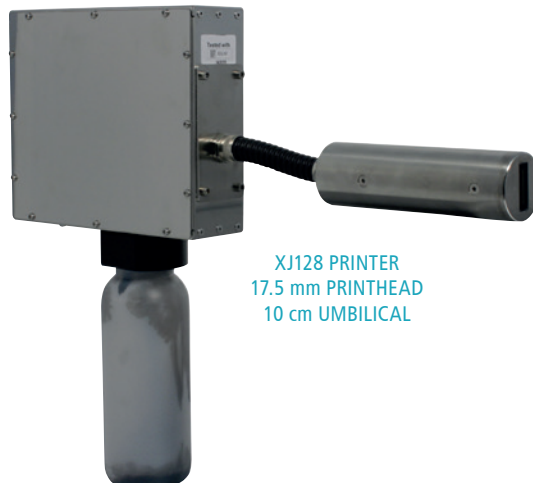
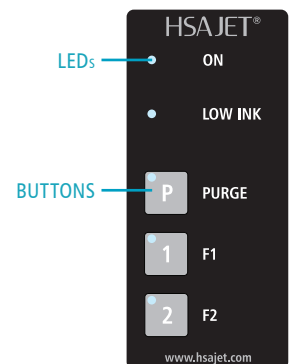
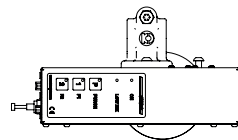
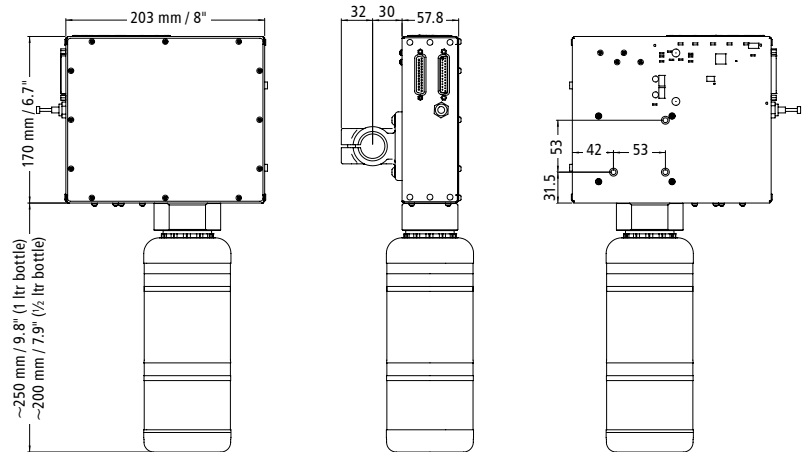

XJ128 PRINTER
17.5 mm PRINTHEAD
10 cm UMBILICAL

Controllers

HSAJET® DOD PRINTERS & CONTROLLERS

CU2

CU2 XAAR XJ128 Controller Unit

The HSAJET® CU2 for HSAJET XAAR printers is a powerful stand-alone controller with keyboard and LCD display. It can control up to 140 mm print height in any head configuration.

You can print counters, date/time, text, graphics, variable barcodes.

Content can be edited directly from the controller or using the built in Ethernet/Serial interface for remote communication.



CU2-XJ128

FLEXIBLE

TIPC15 XJ128 Touch Controller

The TIPC15 has a 15" touch interface and handles any kind of print job, including print from database as well as remote communication via ethernet and serial connection. The jobs are made directly on the unit and controls any combination of print heads up to 280 mm / 11" print height.

Prints variable text, counters, date/time, shift codes, graphics, all barcodes.



TIPC15-XJ128

CB2 / OPC / RPC for XAAR XJ128 print engines

Our flexible solutions are based on our CB2-XJ128 print controller board.

Several choices of controller interface are available; the TIPC15 with one controller board, an office pc or rack pc cabinet with 1 or more controller boards or delivered as an integration kit, which enables customer adapted solutions with multiple cards for additional print height (up to 4 x CB2).



RPC

OPC

Software

All CB2-based controllers are provided with OBJ InkDraw or Mail InkDraw, which give you full database connectivity and one of the most versatile software packages for inkjet printing available in the market.

Print from a wide range of databases, such as *.sql, *.mdb, *.xls and *.csv.



CB2-XJ128

SPECS

Short-Ref	Controller Type	Database	Dim L x W x H (mm)
CU2	CONTROLLER UNIT	no	210 x 155 x 90
TIPC15	TOUCH INDUSTRIAL PRINTER CONTROLLER	yes	372 x 303 x 110
OPC	OFFICE STYLE PRINTER CONTROLLER	yes	420 x 200 x 420
RPC	RACK STYLE PRINTER CONTROLLER	yes	450 x 439 x 177

300-03EN 11/2017

CHECK OUR WEBSITE FOR LATEST REVISION OF THIS DATASHEET

DISTRIBUTOR:



HSA Systems (head offices)

DENMARK | SKOVLUDE +45 4494 0222 | ODENSE +45 6610 3401

HSA Systems (subsidiary offices)

FRANCE +33 1 4815 5050 | GERMANY +49 5257 938 6777

www.hsasystems.com | mail@hsasystems.com