

# Pump Types - HS Automatic Xaar Printers

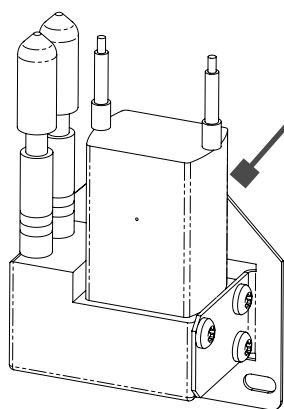

KNF-1CH

Used in :

- **All PRN types (float sensor)**
- AUTO-Xaar 1-2eng
- AUTO-Xaar128 3-4 eng same level
- AUTO-Xaar500 for same level

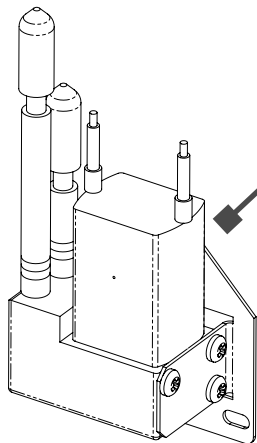

KNF-2CH

Used in:

- AUTO-Xaar128 3-4 eng different level
- AUTO-Xaar500 for different level

Multi-level float sensor ink systems.

This type is only sold in the USA.

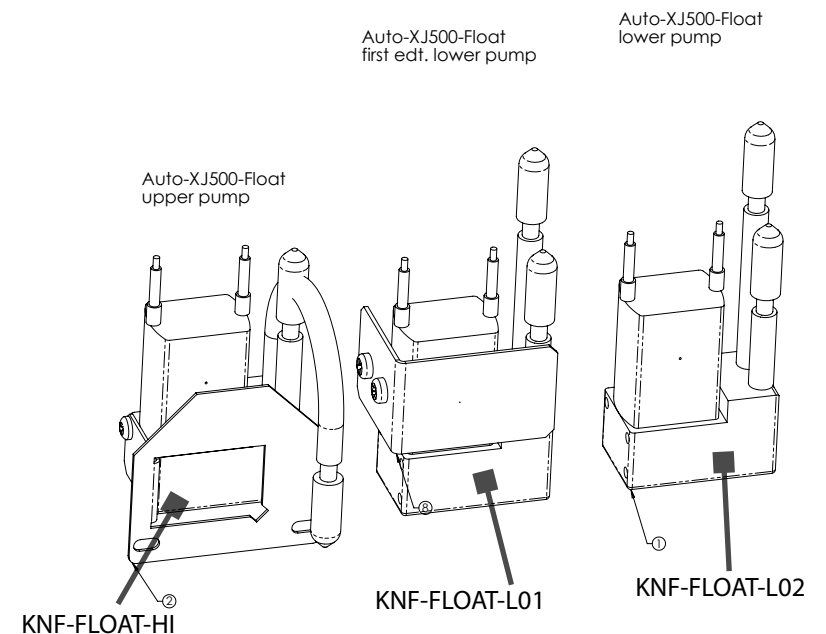

Notice: The actual pump is the same for all configurations. What changes is tubing and metal connected to the pump. If you already have the metal and tubing, you can replace with any pump.