



The TIPC has changed for the better:

Following years of successful service in the industry it is now time to re-launch the Touch Industrial Printer Controller with 15" display (TIPC).



Features of the NEW TIPC15 Touch Industrial Printer Controller

- NEW DESIGN - BLACK ANODIZED ALUMINUM FRAME
- TIPC15 FOR HP HAS THE NEW F-TYPE CONTROLLER BOARD CB-HPF4 BUILT-IN
- TIPC15 FOR HP WORKS WITH F-TYPE PRINT HEADS

What does this mean for you?

The introduction over the past few months of the Fuse Type print head has reduced the number of pen stall failures that are common during incorrect handling of the print heads and cartridges. The fuse type of print head disconnects power as soon as the cartridge is removed from the pen stall, thus almost eliminating the need for costly drive board replacement.

The new design of the controller means that it is cheaper to use in the long run giving longer more operator friendly service.

Technical Changes:

The connection style has changed eliminating the need to use different connections for different pen stalls. All pen stalls now have a DB25 male connector, whether you are using a 1 pen stall or a 4 pen stall, and connecting 2 or more pens is simply done by using a simple distributor box which is available separately.

Technical description - TIPC15HP

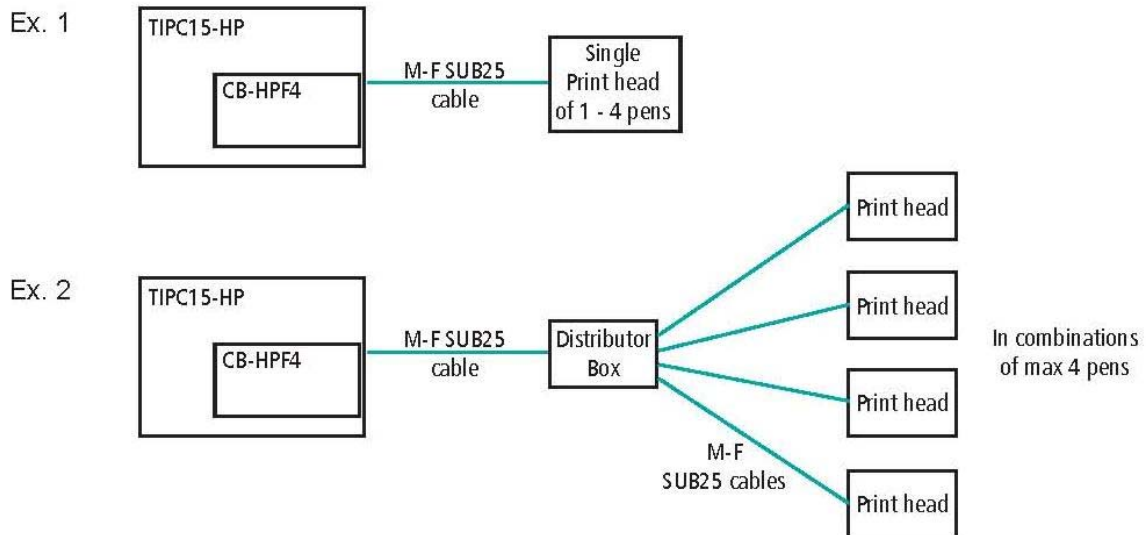

Mounting Information

The TIPC15 comes with an adaptor plate with hole patterns to enable mounting in 2 positions.

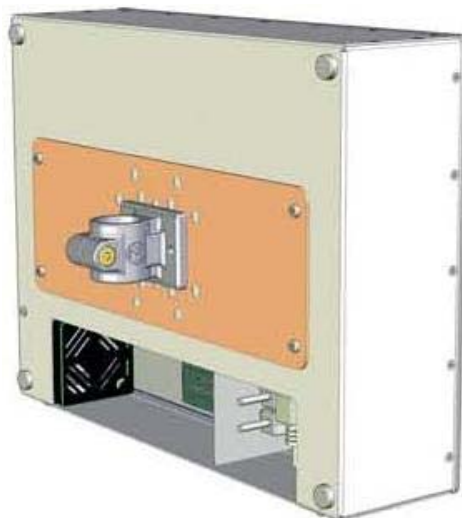

Shown with Optional RFA-1000 Bracket



FAQ

Q: Can we use the original type HP print heads for the TIPC15?

A: Right now you can only use the F-type print heads for the TIPC15. These are the same as used for the Mini Touch. Later on a converter dongle will be available, which enables use of the old type of print heads with the new controllers. At this stage it is not possible to say when this converter will be available.

Q: Will print jobs made on the old TIPC work on the new TIPC15?

A: Yes, there is no change in software or user interface.

Q: What are the power requirements?

A: The new TIPC15 has built-in switch-mode and can therefore be supplied with 100 - 240 VAC.

Q: Does the TIPC15 still run Windows XP and OBJ Inkdraw ?

A: The TIPC15 runs Windows XP and OB INKdraw

Q: What are the dimensions of the controller?

A: The TIPC15 is slightly wider than the old version: W 15 x H 11.5 x D 4.25 ins

Q: Will the old type CB-HP still be available?

A: Yes, for a period of time it can be ordered for use in PC's and for replacement in old type TIPC15's.

Q: Will the new TIPC15 be available with old type Controller Boards?

A: No, there isn't enough space in the TIPC15 for the old type CB-HP.

As always if you have any questions regarding products, sales or service please contact

Jim Teleposky, Sales Manager HSAUSA on 1-800-298-8936 extn 117